

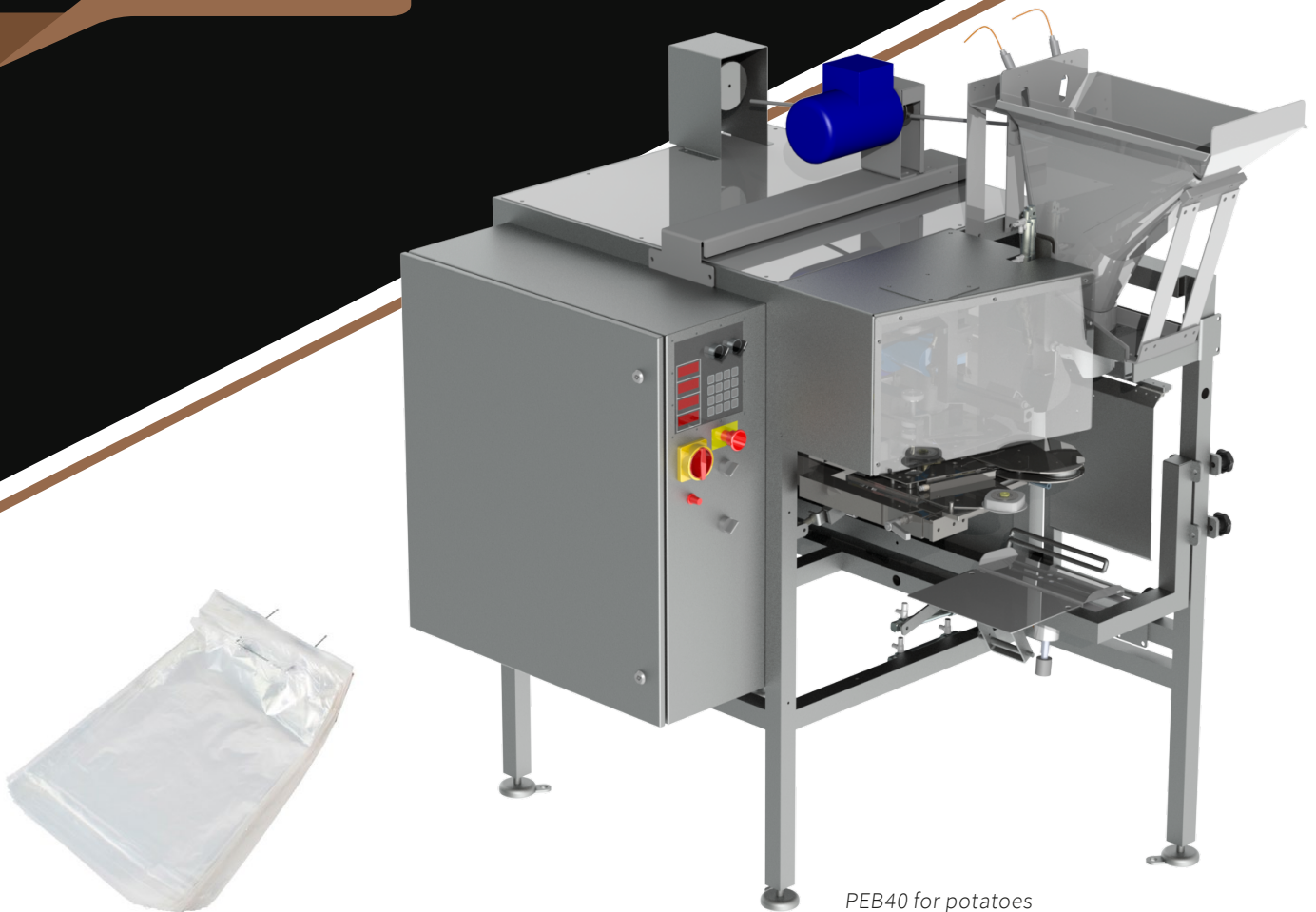

NEWTEC PACKING MACHINE PEB40 SERIES

CUSTOMISED
ACCORDING TO
PACKAGING TYPE
AND PRODUCT



Versatile packing solutions

Advantages

- High Capacity: Up to 25 bags per min.
- Gentle product handling – also for fragile and delicate products
- Customised according to packaging type and product
- Reliable and easy to maintain

Application

For fruits and vegetables packed in wicketed bags e.g.:

- Potatoes • Carrots • Apples
- Similar fruits and vegetables

YOUR ADVANTAGES

- Flexible for various bag sizes
- Prepared for either a Kwik Lok or a tape closing unit
- Efficient twist/cut function after filling

PEB40A for apples with soft fill function during filling

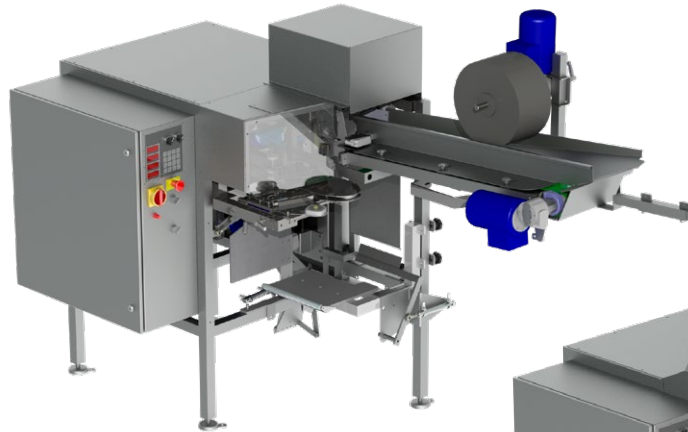

PEB40G for carrots



PREPARED
FOR EITHER A
KWIK LOK OR A
TAPE CLOSING UNIT

PACKING MACHINE FOR WICKETED BAGS

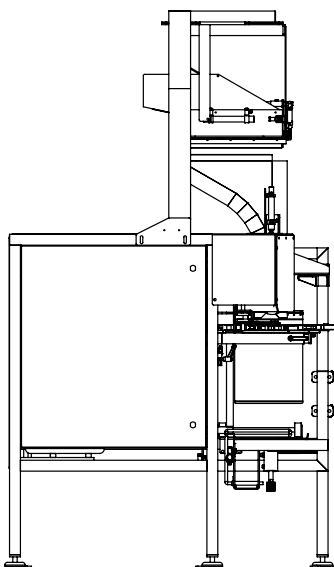

Speed	Up to 25 bags per min.*
Capacity	Weight up to 5 kg
Bag size	H=300mm-550mm W=220mm-320mm
Material	According to the EU rules on food contact materials
Air requirement	
Connection	3/8"
Min. pressure	6 bar (0.6 Mpa)
Consumption	130 NL/min.
Electrical requirement	3x230 VAC or 3x400 VAC (N) PE 50/60 Hz 1 kW
Environment	5°C-40°C
Weight	320 kg

*Speed: depending on model and product

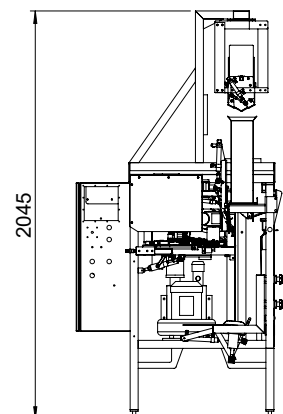
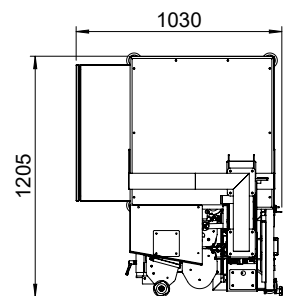

Example of carrot model PEB40G